



Introduction

This application note is dedicated to the output power capability of the STLD41, which is a white LED driver for display backlight. The schematic, functional description and external components selection are also discussed in this application note.

Detailed behavior, if different LED counts on the output and different currents through LEDs are used, is also shown.

Contents

1	Description	3
2	Applications	4
3	Application circuit	5
4	Component calculation	6
	4.1 C_{IN} selection	6
	4.2 C_{OUT} selection	6
	4.3 R_{SENSE} value	6
	4.4 Inductor selection	6
5	Output power capability	8
	5.1 With the LQH6PPN470M3 inductor	8
	5.2 With the MSS1038473MLB inductor	9
	5.3 With the LPS6235473MLB inductor	10
6	Efficiency	11
	6.1 With the LQH6PPN470M3 inductor	11
	6.2 With the MSS1038473MLB inductor	13
	6.3 With the LPS6235473MLB inductor	15
7	Revision history	16

1 Description

The STLD41 is a boost converter that operates from 3.0 V to 21 V and can provide an output voltage as high as 38 V. It can drive up to 40 white LEDs connected in 4 strings of 10 LEDs in series. The total output current capability is 120 mA at an output voltage of 38 V.

Regulation is performed by the internal error amplifier which works with the feedback voltage from the sensing resistor.

The device can be turned ON/OFF by way of the logic signal connected to the EN pin. The Enable pin allows the device to be turned off, so reducing the current consumption to less than 1 μ A.

The LEDs can be dimmed by applying a PWM signal to the PWM pin.

Soft-start with controlled inrush current limit, thermal shutdown and overvoltage protection are integrated functions of the device.

2 Applications

- Mini PCs
- PMP & PND
- Printers
- Game consoles.

Figure 1. Package DFN8 (3 x 3 mm)

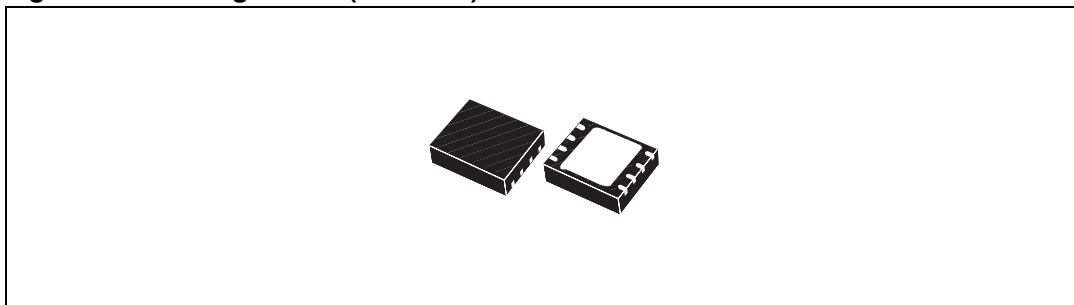

3 Application circuit

Figure 2. Application schematic

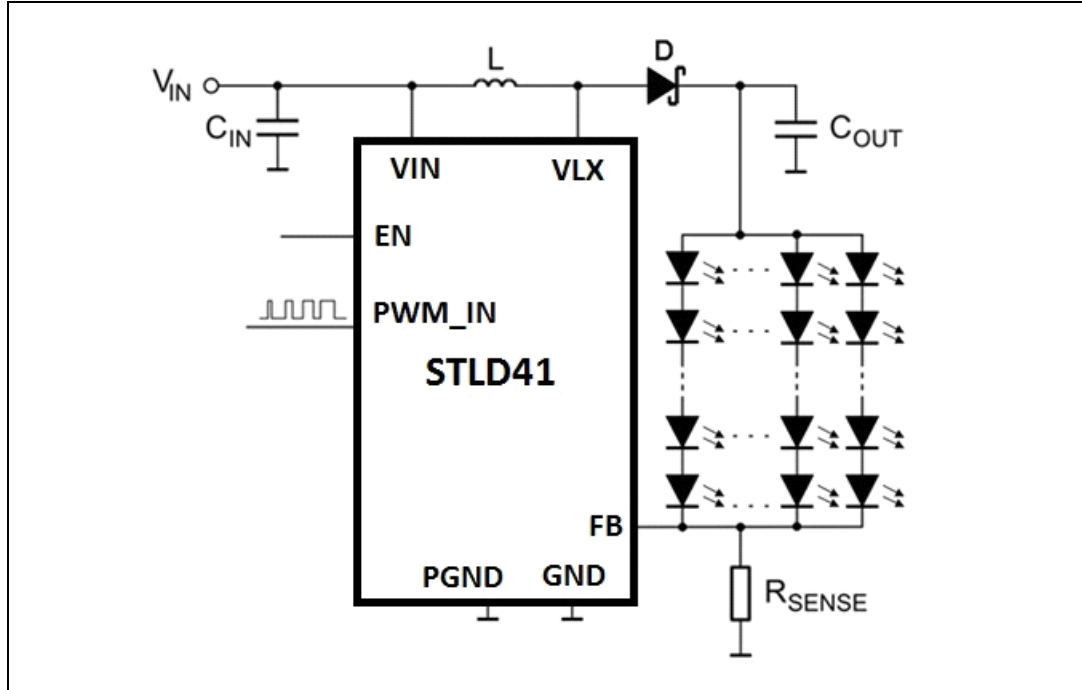

Table 1. List of external components

Comp.	Manufacturer	Part number	Value	Size	Ratings
L	CoilCraft Murata CoilCraft	LPS6235473MLB LQH6PPN470M43 MSS1038473MLB	47 μ H	6 x 6 x 3.5 mm 6 x 6 x 4.3 mm 10 x 10 x 3.8 mm	I = 1.2 A, DCR = 0.245 Ω I = 1.25 A, DCR = 0.23 Ω I = 2.22 A, DCR = 0.13 Ω
C _{IN}	Murata	GRM32ER71H106K	10 μ F	1210	\pm 10%, X7R, 50 V
C _{OUT}	Murata	GRM31CR61H225KA88L	2.2 μ F	1206	\pm 15%, X5R, 50 V
D	STMicroelectronics	STPS1L40M	1 A	3.75 x 1 x 1.9 mm	40 V
R _{SENSE}			0.4 Ω – 1.6 Ω	0603	

4 Component calculation

4.1 C_{IN} selection

It is recommended to use 10 μF as the input capacitor to achieve good stability of the device and low noise on the V_{IN} track.

4.2 C_{OUT} selection

It is recommended to use 2.2 μF as the optimal value of the output capacitor to get the best compromise between output voltage ripple and load transient response.

4.3 R_{SENSE} value

$$R_{SENSE} = V_{REF} / I_{LED}$$

R_{SENSE} sensing resistor

V_{REF} reference voltage = 160 mV typical

I_{LED} total LED output current

$$P_{RSENSE} = R_{SENSE} * I_{LED}^2$$

P_{RSENSE} power dissipation of the sensing resistor

Table 2. R_{SENSE} calculated values

I _{LED}	100	150	200	250	300	350	400
R _{SENSE}	1.6 Ω	1.1 Ω	0.8 Ω	0.65 Ω	0.55 Ω	0.45 Ω	0.4 Ω

4.4 Inductor selection

A thin shielded inductor with a low DC series resistance of winding is recommended for this application. To achieve a good efficiency in step-up mode, it is recommended to use an inductor with a DC series resistance R_{DCL} = R_D / 10 [Ω, Ω, 1], where R_D is the dynamic resistance of the LED.

Equation 1

$$I_{PEAK} = \left\{ \left(\frac{I_{OUT}}{\eta} \right) + \frac{[(V_{OUT} - V_{IN}) * V_{IN}^2]}{2 * L * f * V_{OUT}^2} \right\} * \frac{V_{OUT}}{V_{IN}}$$

where:

I_{PEAK} is peak inductor current

I_{OUT} is current sourced at the V_{OUT} pin

η is the efficiency of the STLD41

V_{OUT} is output voltage at the V_{OUT} pin

V_{IN} is input voltage at the V_{BAT} pin

L is inductance value of the inductor

f is the switching frequency.

5 Output power capability

All measurements were made at ambient temperature (24 °C) and 3 different inductors.

5.1 With the LQH6PPN470M3 inductor

Figure 3. Current capability with the LQH6PPN470M3

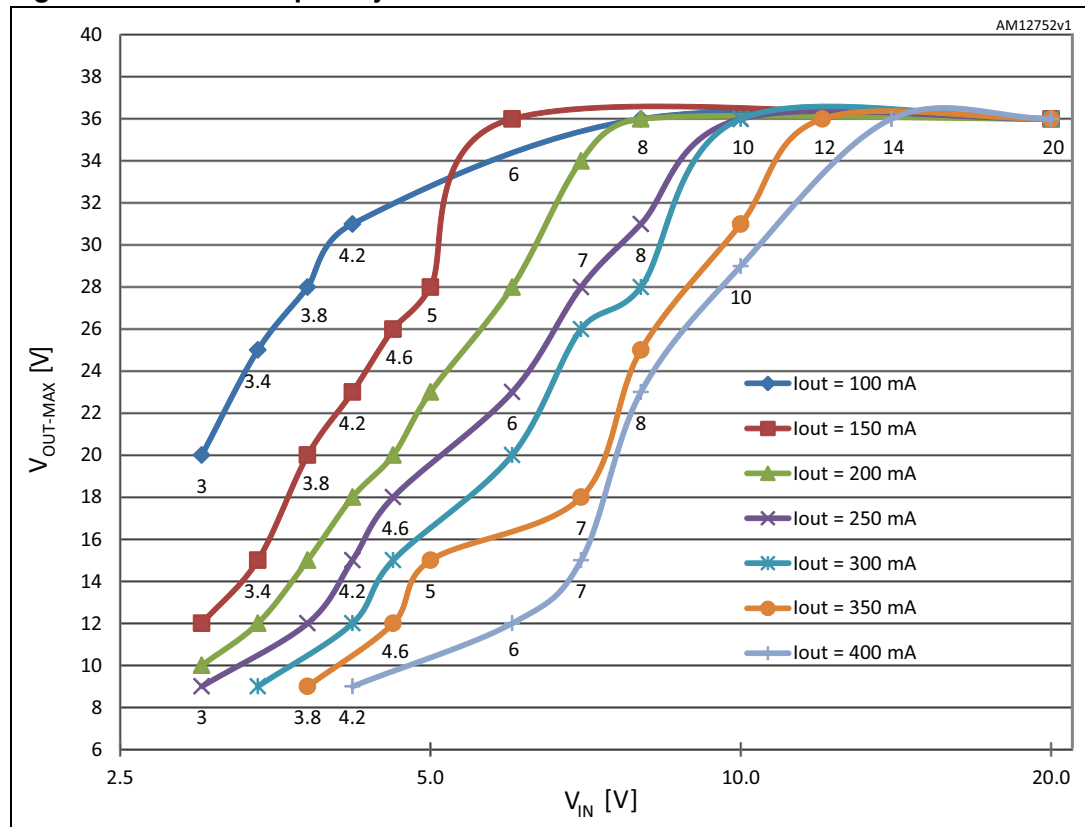

5.2 With the MSS1038473MLB inductor

Figure 4. Current capability with the MSS1038473MLB

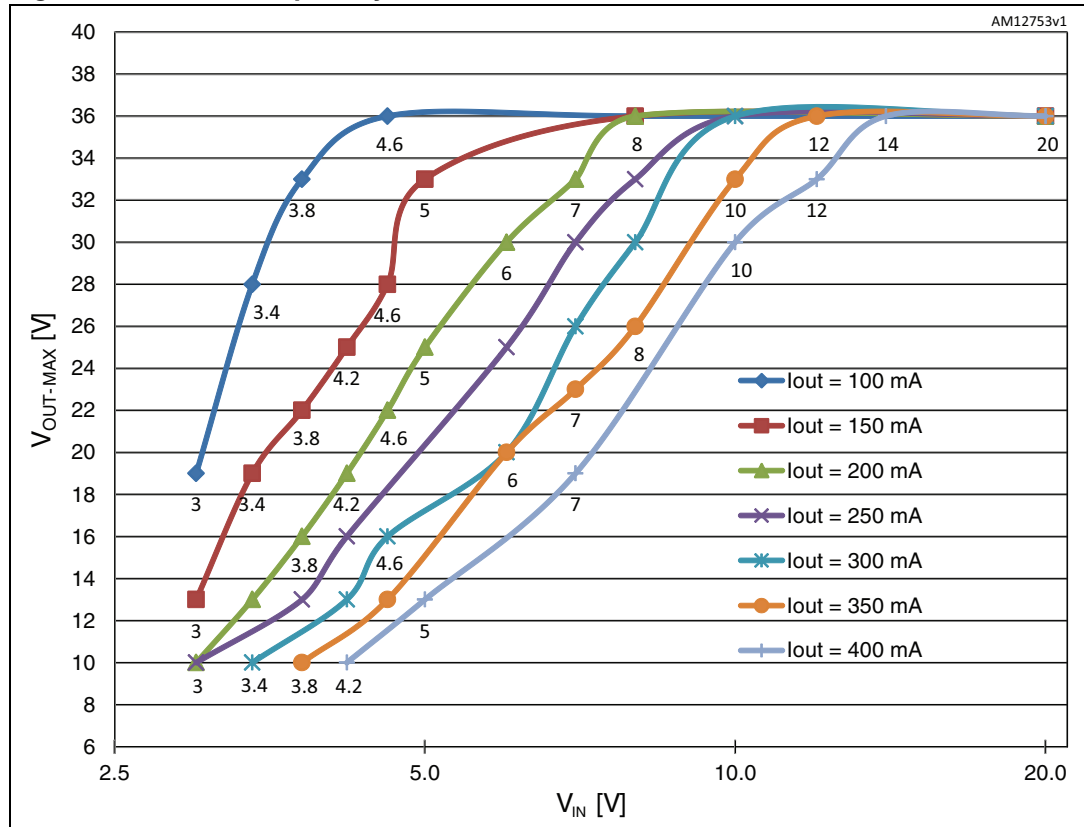

5.3 With the LPS6235473MLB inductor

Figure 5. Current capability with the LPS6235473MLB

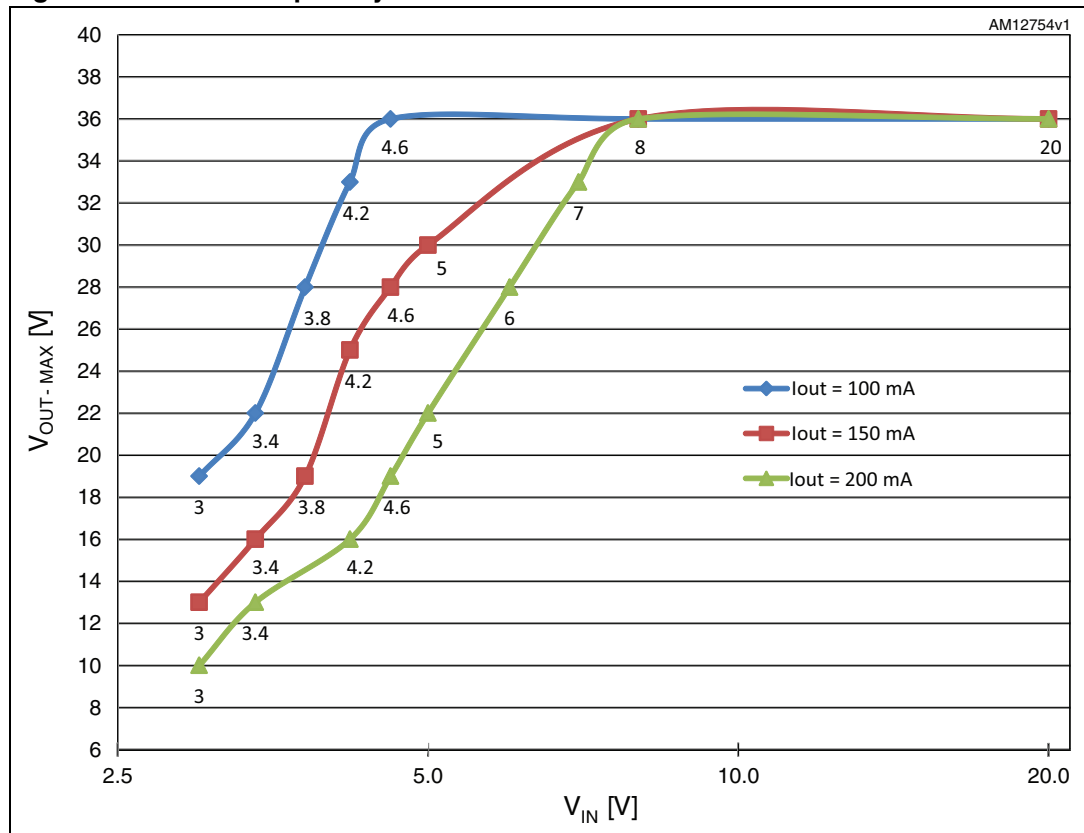

6 Efficiency

6.1 With the LQH6PPN470M3 inductor

Figure 6. $I_{OUT} = 100\text{ mA}$ with the LQH6PPN470M3

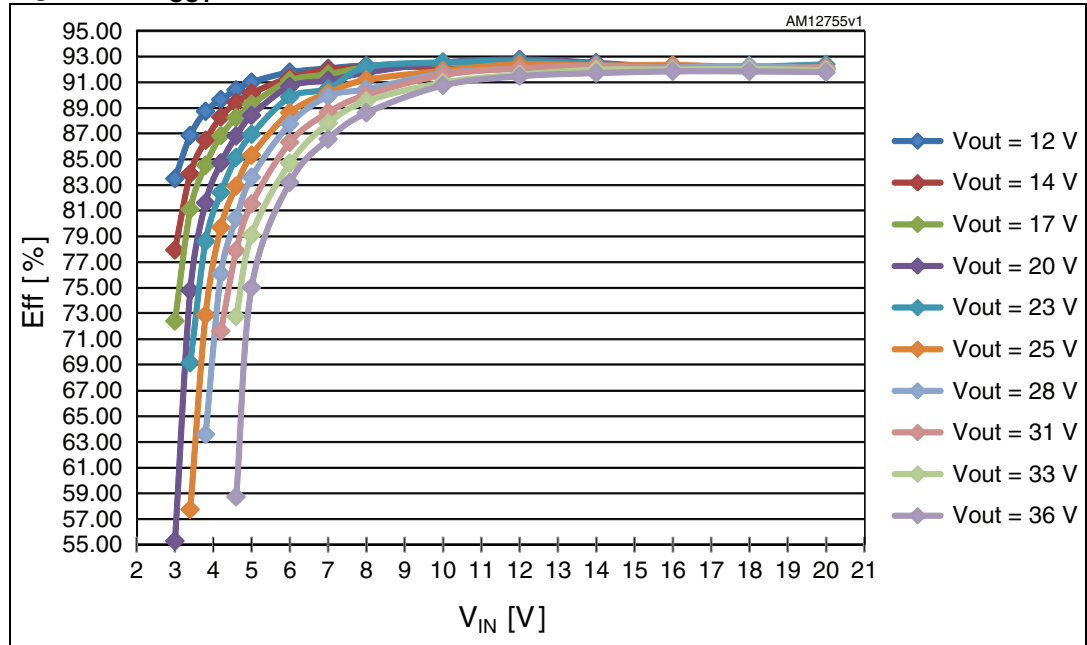

Figure 7. $I_{OUT} = 200\text{ mA}$ with the LQH6PPN470M3

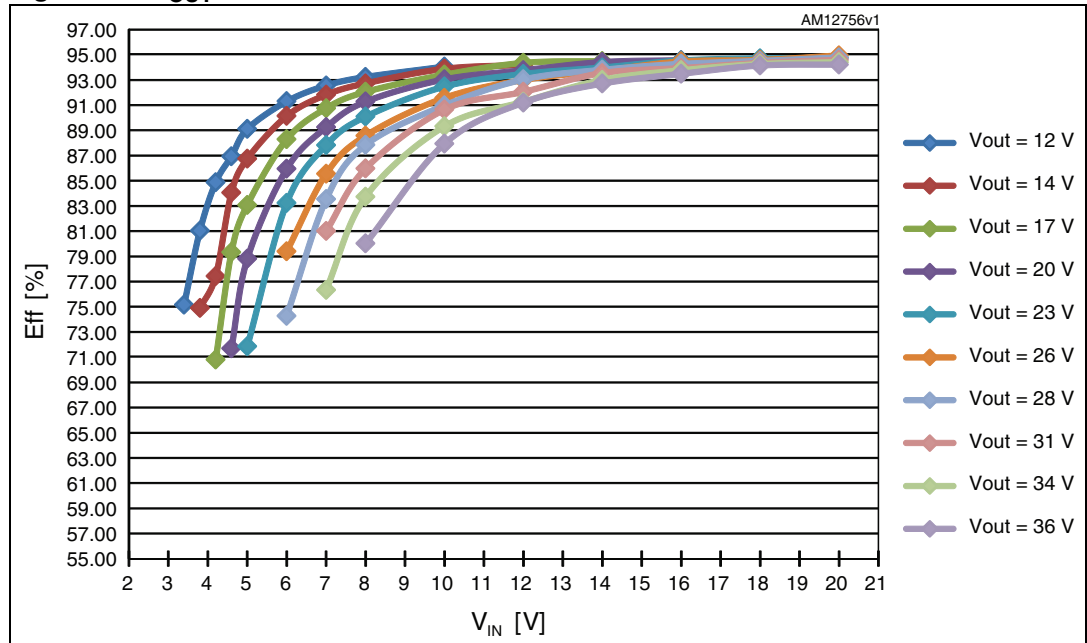

Figure 8. $I_{OUT} = 300\text{ mA}$ with the LQH6PPN470M3

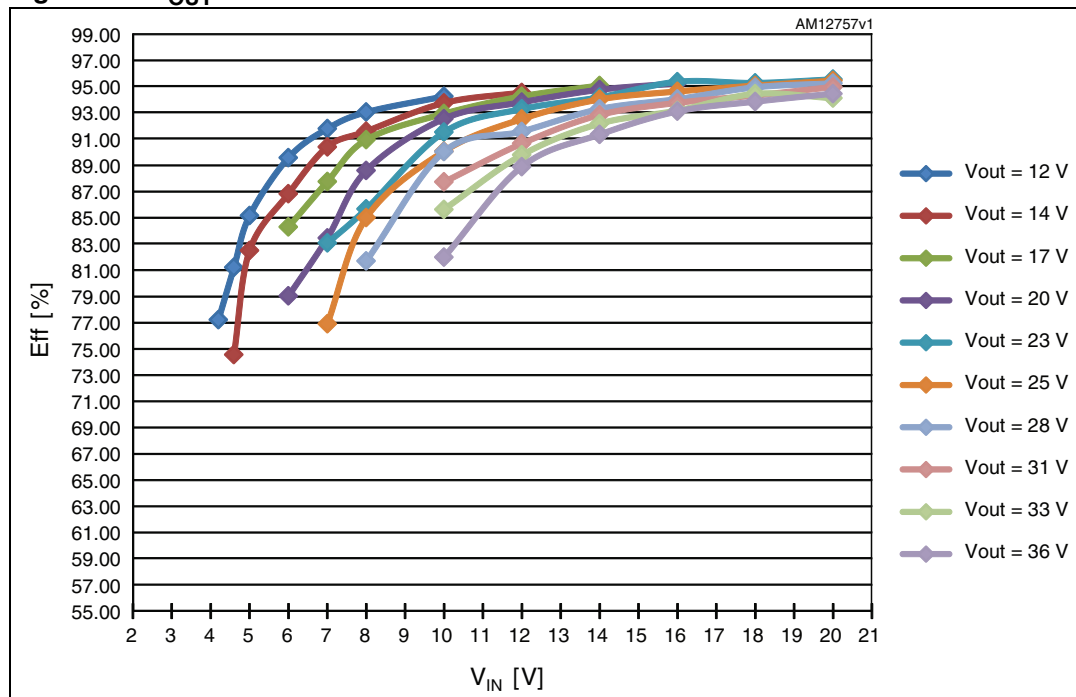
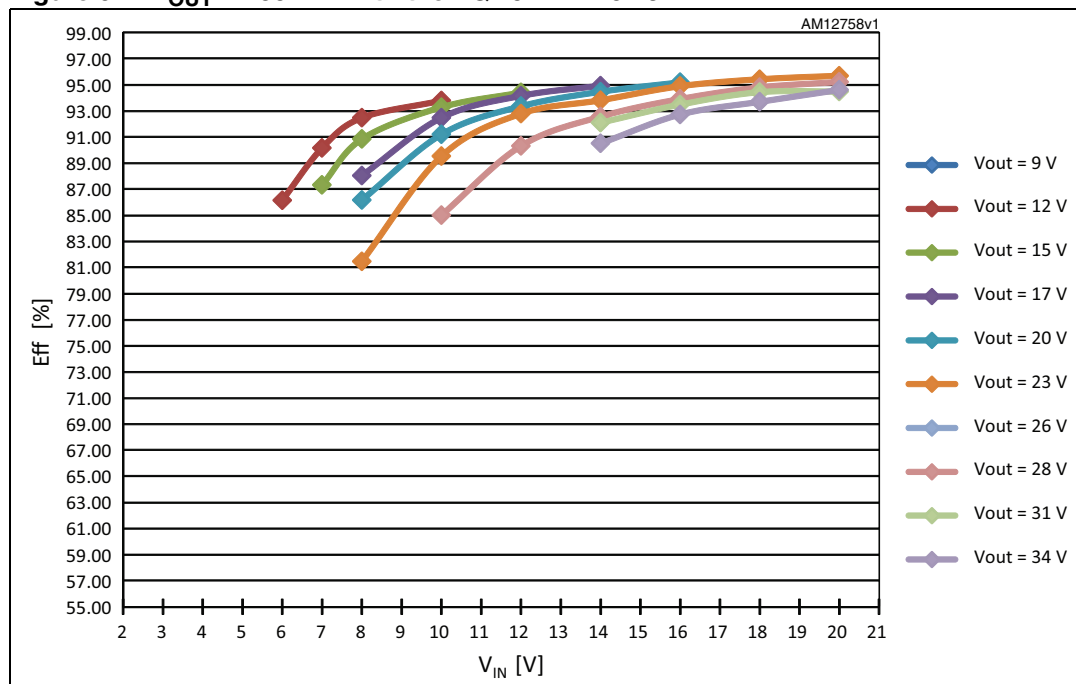

Figure 9. $I_{OUT} = 400\text{ mA}$ with the LQH6PPN470M3



6.2 With the MSS1038473MLB inductor

Figure 10. $I_{OUT} = 100\text{ mA}$ with the MSS1038473MLB

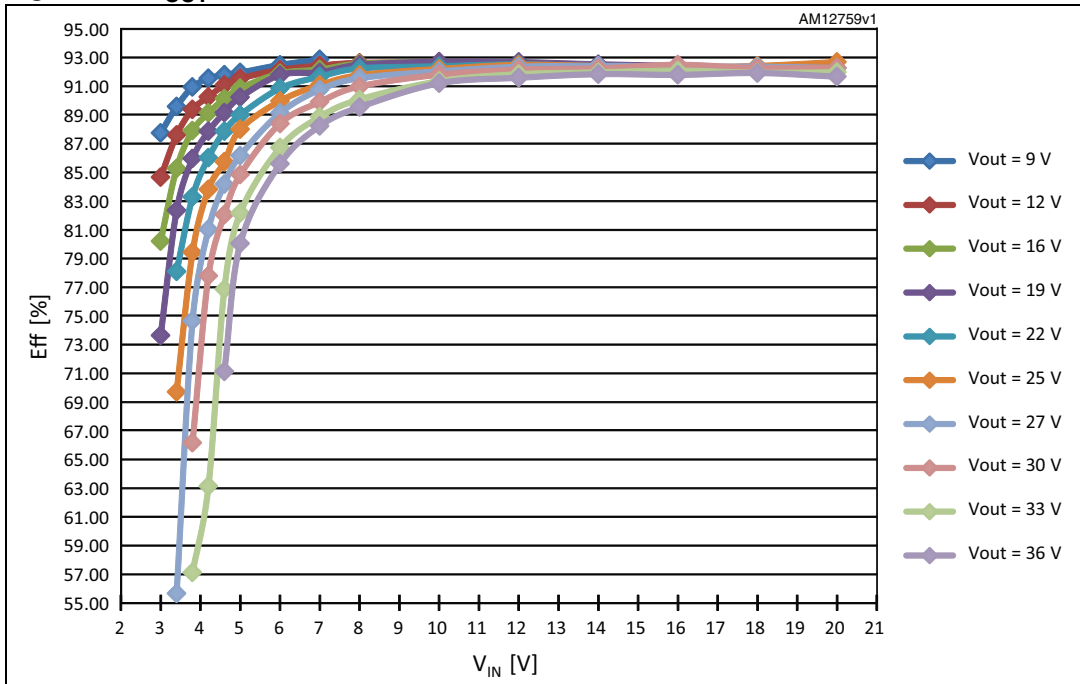

Figure 11. $I_{OUT} = 200\text{ mA}$ with the MSS1038473MLB

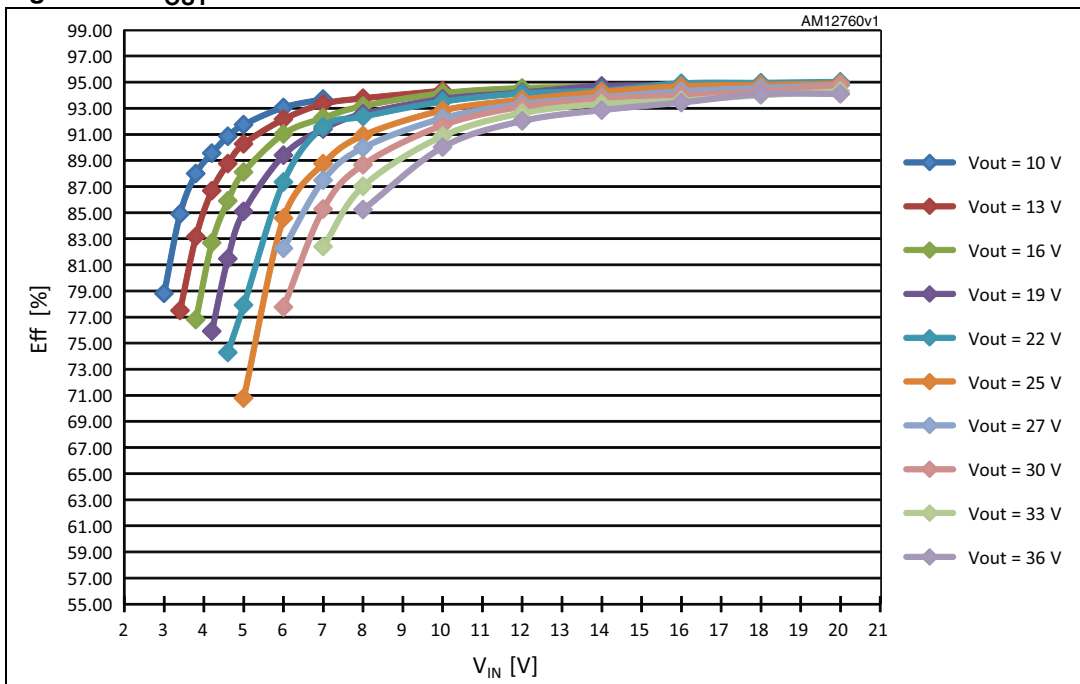

Figure 12. $I_{OUT} = 300\text{ mA}$ with the MSS1038473MLB

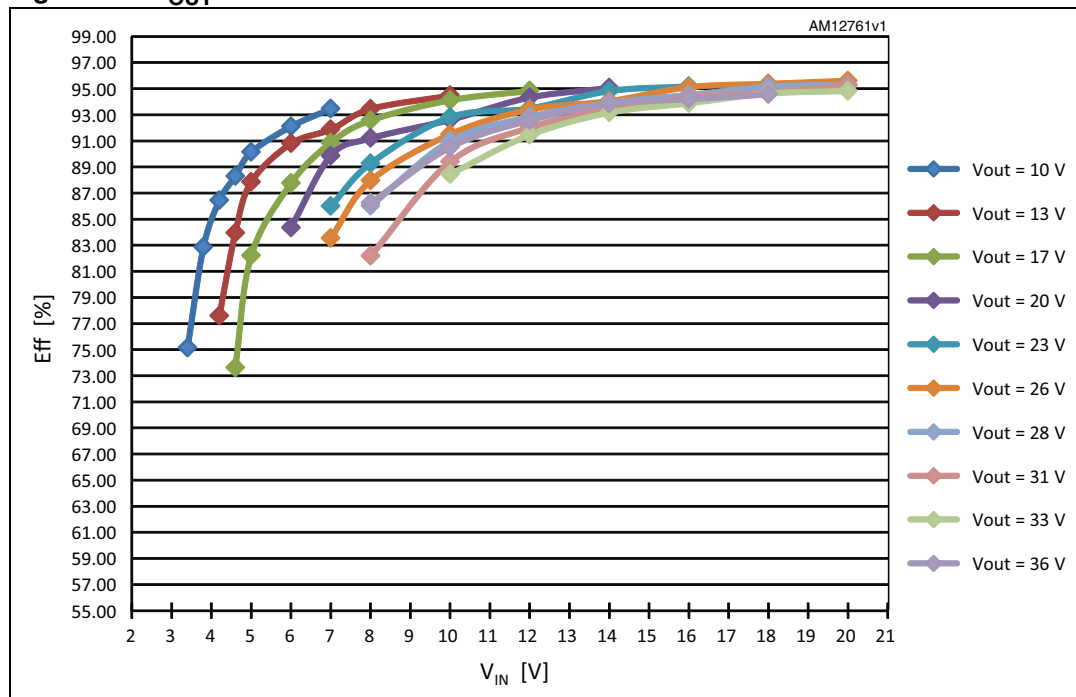
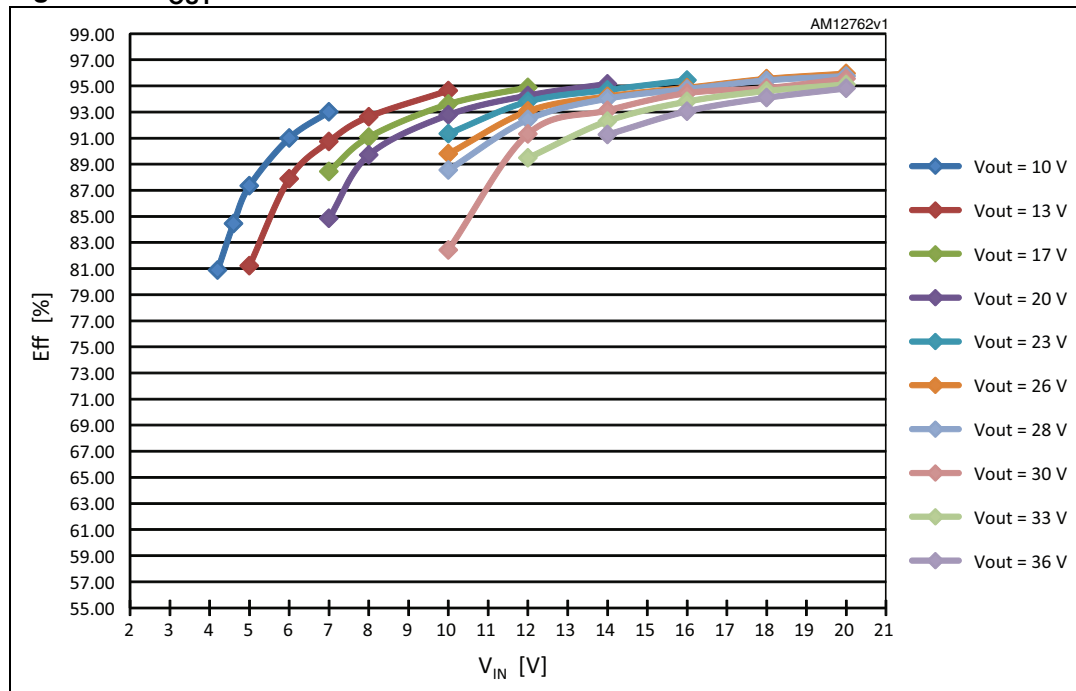

Figure 13. $I_{OUT} = 400\text{ mA}$ with the MSS1038473MLB



6.3 With the LPS6235473MLB inductor

Figure 14. $I_{OUT} = 100\text{ mA}$ with the LPS6235473MLB

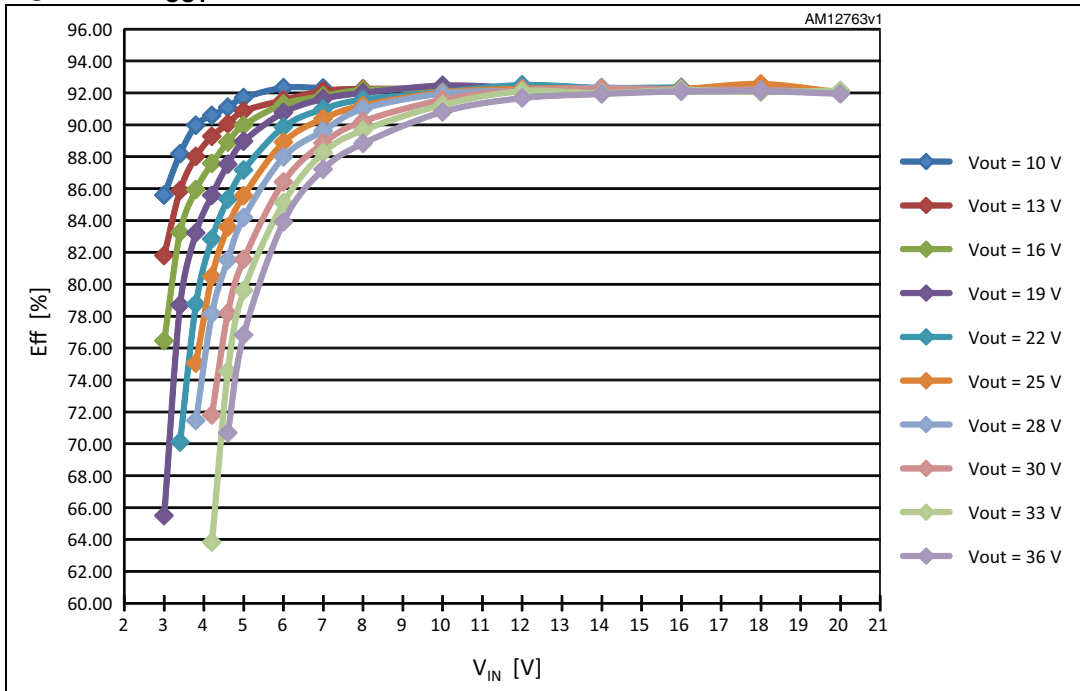
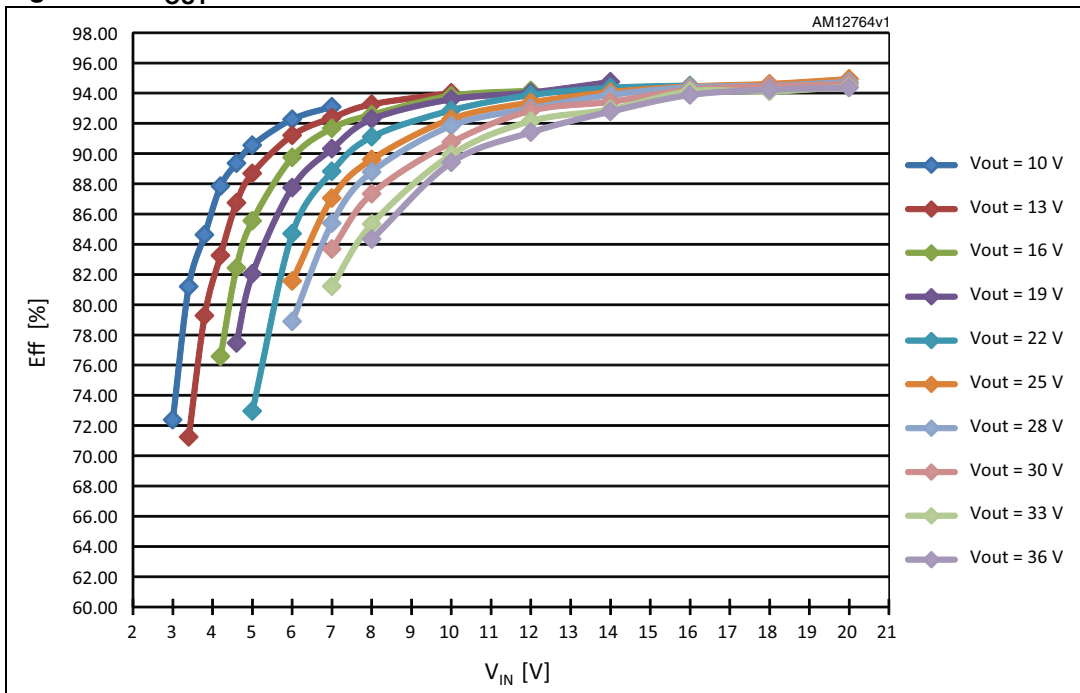

Figure 15. $I_{OUT} = 200\text{ mA}$ with the LPS6235473MLB



7 Revision history

Table 3. Document revision history

Date	Revision	Changes
28-Aug-2012	1	Initial release.

Please Read Carefully:

Information in this document is provided solely in connection with ST products. STMicroelectronics NV and its subsidiaries ("ST") reserve the right to make changes, corrections, modifications or improvements, to this document, and the products and services described herein at any time, without notice.

All ST products are sold pursuant to ST's terms and conditions of sale.

Purchasers are solely responsible for the choice, selection and use of the ST products and services described herein, and ST assumes no liability whatsoever relating to the choice, selection or use of the ST products and services described herein.

No license, express or implied, by estoppel or otherwise, to any intellectual property rights is granted under this document. If any part of this document refers to any third party products or services it shall not be deemed a license grant by ST for the use of such third party products or services, or any intellectual property contained therein or considered as a warranty covering the use in any manner whatsoever of such third party products or services or any intellectual property contained therein.

UNLESS OTHERWISE SET FORTH IN ST'S TERMS AND CONDITIONS OF SALE ST DISCLAIMS ANY EXPRESS OR IMPLIED WARRANTY WITH RESPECT TO THE USE AND/OR SALE OF ST PRODUCTS INCLUDING WITHOUT LIMITATION IMPLIED WARRANTIES OF MERCHANTABILITY, FITNESS FOR A PARTICULAR PURPOSE (AND THEIR EQUIVALENTS UNDER THE LAWS OF ANY JURISDICTION), OR INFRINGEMENT OF ANY PATENT, COPYRIGHT OR OTHER INTELLECTUAL PROPERTY RIGHT.

UNLESS EXPRESSLY APPROVED IN WRITING BY TWO AUTHORIZED ST REPRESENTATIVES, ST PRODUCTS ARE NOT RECOMMENDED, AUTHORIZED OR WARRANTED FOR USE IN MILITARY, AIR CRAFT, SPACE, LIFE SAVING, OR LIFE SUSTAINING APPLICATIONS, NOR IN PRODUCTS OR SYSTEMS WHERE FAILURE OR MALFUNCTION MAY RESULT IN PERSONAL INJURY, DEATH, OR SEVERE PROPERTY OR ENVIRONMENTAL DAMAGE. ST PRODUCTS WHICH ARE NOT SPECIFIED AS "AUTOMOTIVE GRADE" MAY ONLY BE USED IN AUTOMOTIVE APPLICATIONS AT USER'S OWN RISK.

Resale of ST products with provisions different from the statements and/or technical features set forth in this document shall immediately void any warranty granted by ST for the ST product or service described herein and shall not create or extend in any manner whatsoever, any liability of ST.

ST and the ST logo are trademarks or registered trademarks of ST in various countries.

Information in this document supersedes and replaces all information previously supplied.

The ST logo is a registered trademark of STMicroelectronics. All other names are the property of their respective owners.

© 2012 STMicroelectronics - All rights reserved

STMicroelectronics group of companies

Australia - Belgium - Brazil - Canada - China - Czech Republic - Finland - France - Germany - Hong Kong - India - Israel - Italy - Japan - Malaysia - Malta - Morocco - Philippines - Singapore - Spain - Sweden - Switzerland - United Kingdom - United States of America

www.st.com

